



# P-LIGHT Charging Kit Magnum Frame

en Information about P-LIGHT Charging Kit.

See our website – [support.p-light.com](http://support.p-light.com) – for support and technical information



# P-LIGHT Charging Kit



Charger input cable 230V, 0.5 or 1.0 m



Charger connection cable 230V, 5 meters

## Battery Charger

The battery charger is designed for both internal and external mounting on vehicles and for approved installation the installation description must be followed. The charger is intended for rechargeable lead batteries with a capacity greater than 30Ah, and approved for fixed installation in motor vehicles with a 24V electrical system and negative ground (minus to goods).

When charging, there is no need to unscrew the battery cell plugs or dismantle the battery cables. The charger is designed to charge at low temperatures.

The battery manufacturer's instructions for care, refilling with distilled water, cleaning, etc. must be followed.

The battery charger has an electronically controlled charging curve with advanced charging technology that protects the battery against overcharging and enables connection for longer periods.

## Technical data IE8700-12

- for 24 V DC system
- input voltage 230 V, power 300 W max. 2A
- charging voltage 28.8 V / 27.6 V (fast/slow)
- charging current 12 A
- recommended battery capacity 30-300 Ah (suitable for lead batteries including AGM batteries)
- built-in protection against short circuit and incorrect connection
- 20 A fuse on the 24 V side
- 24 V connection cables 1.5 m, M8 ring cable lug
- operating temperature -40...+60 °C
- protection class IP46
- dimensions L 192 x W 98 x H 49 mm
- weight 1.5 kg

## Dimensions and Facts

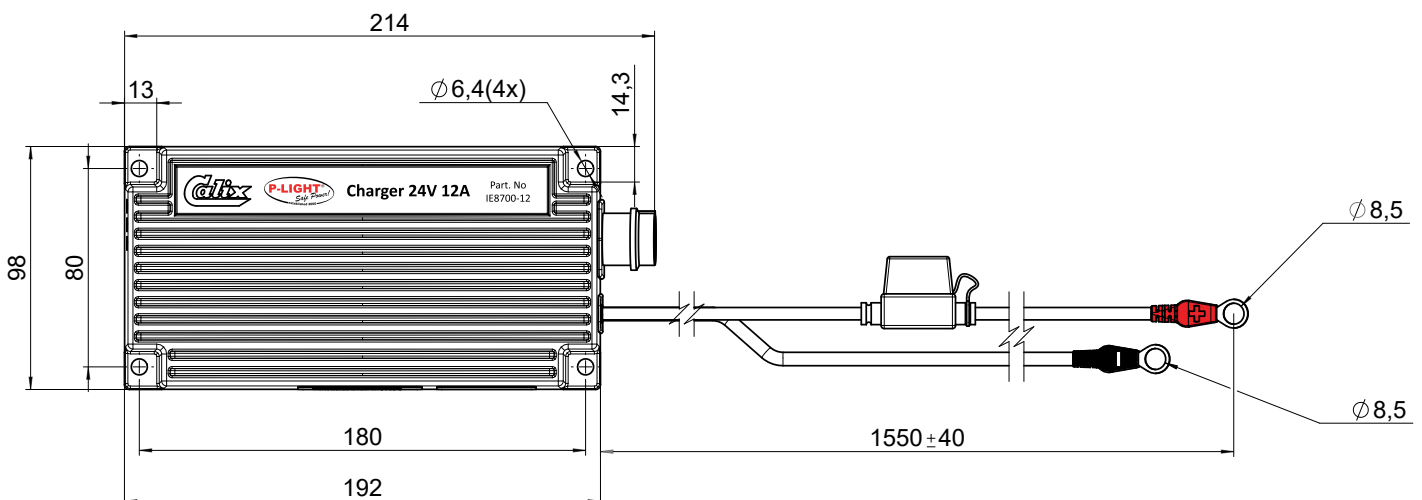

## P-LIGHT Magnum Frame Mounting and Mounting Plate

When installing and using the Calix installation and operating instructions must be followed to ensure installation, assembly and operation.

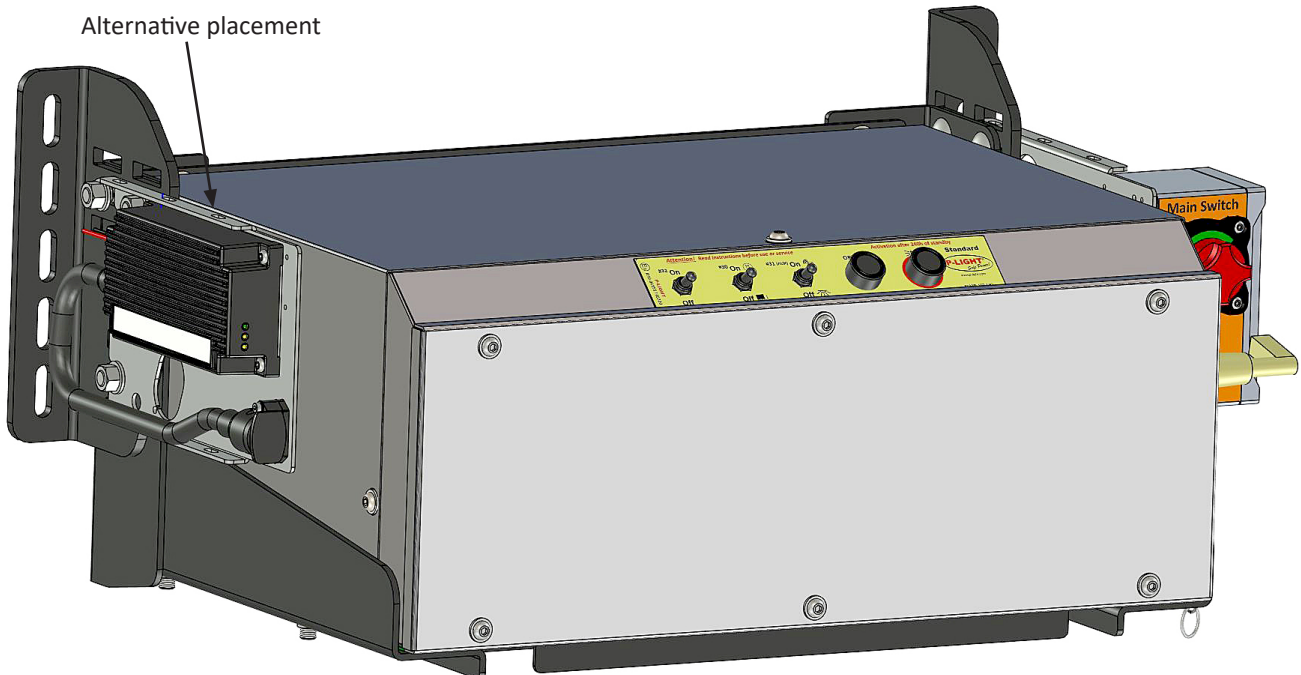
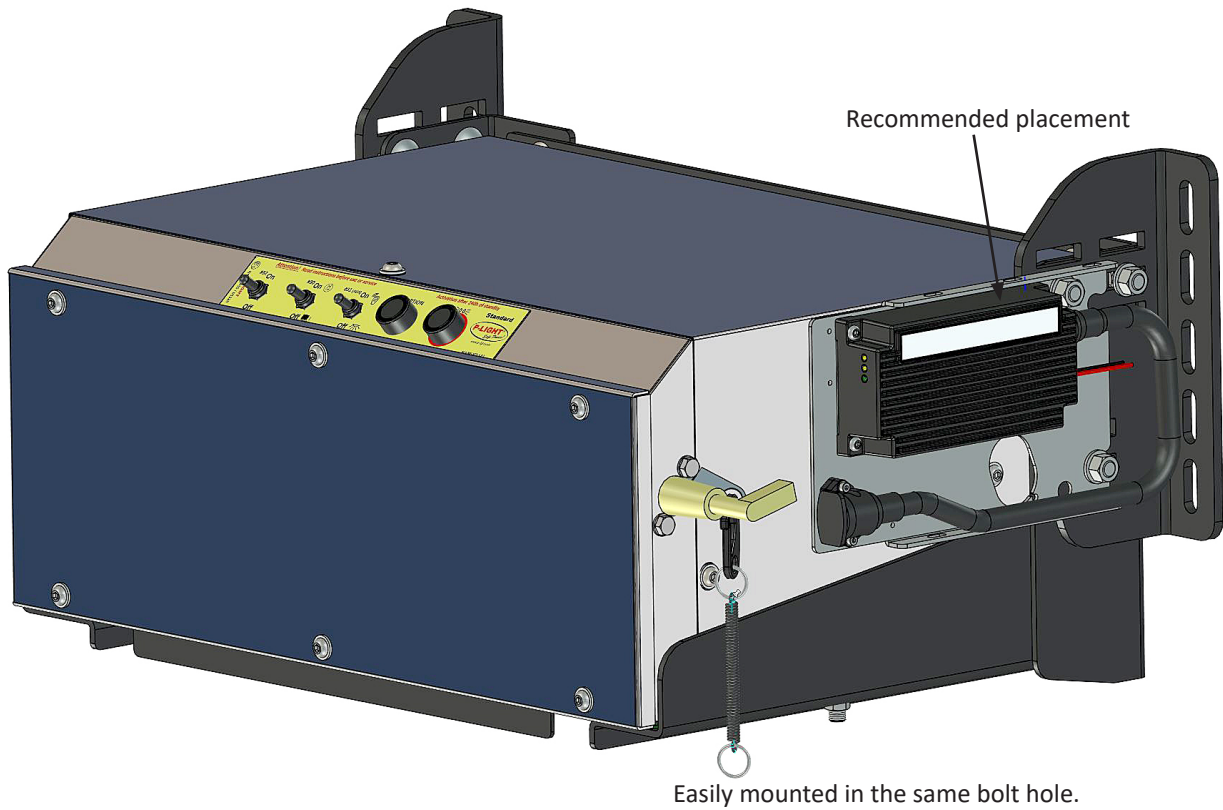

## P-LIGHT Battery Pack

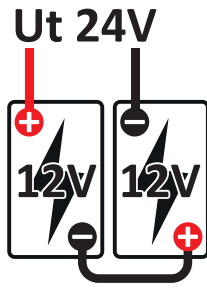

The P-LIGHT Battery pack is 24V with 2x series connected 12V batteries and is available from 18 to 200Ah. When connecting in series, the batteries should be of the same size, quality and age. Both batteries must be replaced at the same time.

The P-LIGHT Battery is an extremely good AGM-type operating battery especially developed for and together with P-LIGHT as well as for the operation of equipment on vehicles and towed vehicles with many charging cycles that provide reliability and long life.

### Charging



The P-LIGHT Battery Pack normally charged by a built-in intelligent charger in the P-LIGHT control unit/control units

### External charging

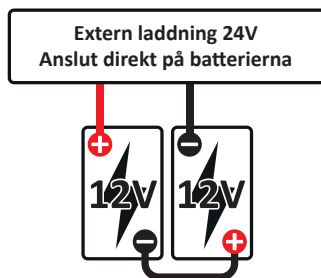

External charging should be cross-charged, this means connecting plus on one battery and minus on the other battery – then the charge goes through both batteries and are charged at the same time. Charging should be with A up to 20% of the size of the battery bank

For example, 18Ah with >5A, 45Ah with >10A, 150Ah with >30A and 200Ah with >40A charging.

**NOTE!** If the C11 or CC1 error code has been displayed and external charging is being done, the error code will appear again. Restarting the charger requires around 5 minutes of voltage on input terminals 4 and 6 of the controller (truck connected and lighting on).

### Battery testing

Battery test equipment for e.g. CCA rating is for traditional starter batteries and is a way to measure cold start characteristics. The batteries developed for and together with P-LIGHT do not have these characteristics and therefore no measurement values for this type of health test. However, this test equipment can detect e.g. cell faults that create other battery problems.

## Battery facts

### Introduction

The battery volts tell you which voltage the battery is delivering and is charged with while the ampere hours, Ah, indicates about how much energy the battery contains. A battery consists of cells. One cell can emit a maximum of 2.14V, which means that in a 12V battery, for example, there are six cells.

The three most common types of batteries are wet, AGM and gel battery. These can also be divided into two classes depending on the area of use, starter or operating battery. A starter battery is made to provide a lot of energy for short periods while an operating battery is suitable for providing more even current for longer periods.

### Wet batteries

The type of batteries that most people think of when it comes to a battery. The acid and electrolyte are in liquid form and move freely between the lead plates. The peculiarity of a wet battery is that the electrolyte, or battery water, needs to be refilled periodically. A wet battery can be used for both as starter and operation. It is often of slightly poorer quality and if they are not used or maintained correctly, the battery can emit a flammable gas. A wet battery should never be discharged more than 50% as they will then be damaged.

### AGM batteries

What is special about AGM is that all the liquid, both the acid and the electrolyte, is bound in a weave located between the lead plates. As it contains no liquid, an AGM battery is maintenance-free, i.e. no liquid needs to be refilled. The cells are also encapsulated, which means that the battery is very safe. An AGM battery is perfect both as a starter and for operation. A well-maintained AGM can last for up to 600 charge cycles. An AGM battery must never be left uncharged, as it will be damaged.

### Gel batteries

A gel battery is very similar to an AGM battery. They have the same properties, while what distinguishes them is that the liquid is not bound in a weave but is in gel form, and that a gel battery can be used a little more as it can use 60% of the battery before it needs recharging. It is also more suitable to use as an operating battery.

### How to prevent deep discharge?

Use a battery monitor to avoid deep discharge of a battery. It disconnects the batteries before they discharge too much, which means that the batteries are not damaged.

### What affects the life of a battery?

There are several things that affect life expectancy, i.e. the amount of sulphating, here is a list of some factors that affect life expectancy:

Temperature – Most batteries are made to operate at about +20C. A battery that is in +30C, e.g. in a machine room, is down to 50% life expectancy and at +40C there is only 30% of life expectancy left.

Depth of discharge – A battery should never be discharged completely. A wet battery should never be discharged more than 50% of its capacity.

The number of discharge cycles – A battery has a predetermined lifespan that is measured in charge cycles.

Installation quality – is the right cable being used? Charging with the right type of charger?

Charge control – Temperature affecting battery charging? Higher charger voltage required when cold.



Manufacturer  
InnoNet AB - Olvågen 7 - SE-342 50 Vislanda  
Phone +46 472-483 83  
www.innonet.se